

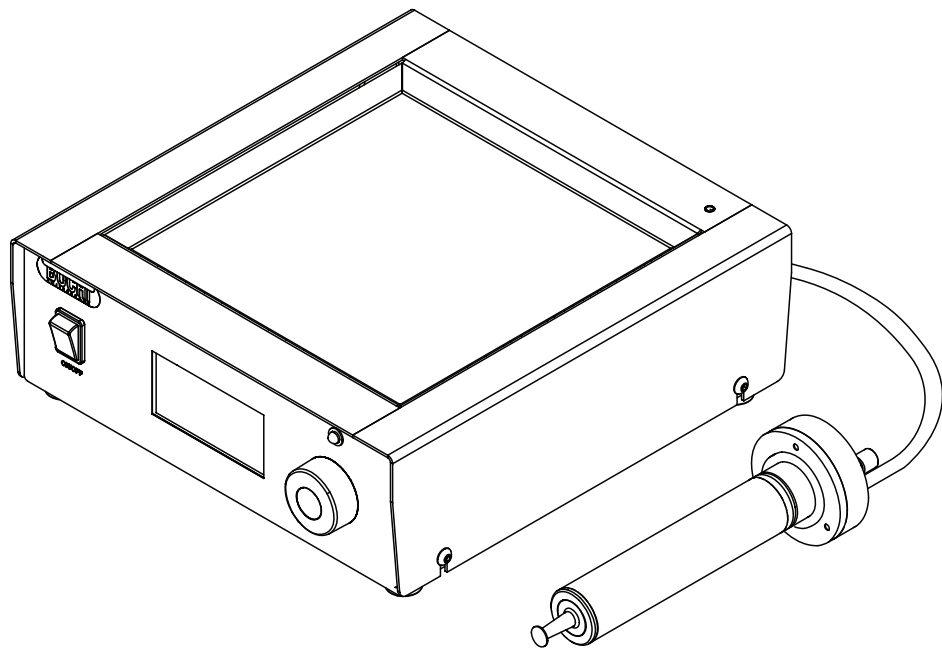

Ultrasonic Package Operation Manual



Imprint

Product Identification:
Operation Manual (Original) Ultrasonic Package
11594107

Publication date: 01.2020

BÜCHI Labortechnik AG
Meierseggrasse 40
Postfach
CH-9230 Flawil 1

E-Mail: quality@buchi.com

BÜCHI reserves the right to make changes to the manual as deemed necessary in the light of experience, especially with respect to structure, illustrations and technical details.

This manual is copyrighted. Information from it may neither be reproduced, distributed, or used for competitive purposes, nor made available to third parties. The manufacture of any component with the aid of this manual without prior written agreement is also prohibited.

Table of contents

1	About this document.....	5
1.1	Warning notices in this document.....	5
1.2	Connected devices.....	5
1.3	Symbols.....	5
1.3.1	Warning symbols.....	5
1.3.2	Mark-ups and symbols.....	6
1.4	Trademarks.....	6
2	Safety.....	7
2.1	Proper use.....	7
2.2	Use other than that intended.....	7
2.3	Staff qualification.....	7
2.4	Location of warning signs on the product.....	8
2.5	Residual risks.....	8
2.5.1	Faults during operation.....	8
2.5.2	Hot surfaces.....	9
2.5.3	Dangerous vapors.....	9
2.6	Personal protective equipment.....	9
2.7	Modifications.....	9
3	Product description.....	10
3.1	Description of function.....	10
3.2	Configuration.....	10
3.2.1	Front view ultrasonic controller.....	10
3.2.2	Rear view ultrasonic controller.....	11
3.2.3	Ultrasonic nozzle.....	11
3.3	Type plate.....	12
3.4	Scope of delivery.....	12
3.5	Technical data.....	12
3.5.1	Ultrasonic controller.....	12
3.5.2	Ultrasonic nozzle.....	12
3.5.3	Ambient conditions.....	13
3.5.4	Materials.....	13
4	Transport and storage.....	14
4.1	Transport.....	14
4.2	Storage.....	14
5	Installation.....	15
5.1	Before installation.....	15
5.2	Installation site.....	15
5.3	Establishing electrical connections.....	15
5.4	Installing the ultrasonic controller.....	16
5.5	Installing the ultrasonic nozzle in open mode.....	16
5.6	Installing the ultrasonic nozzle in closed mode.....	18

6	Operation.....	22
6.1	Operating the display.....	22
6.1.1	Layout of the display.....	22
6.1.2	Entering settings.....	22
6.1.3	Selecting the operation mode.....	22
6.2	Finding the optimal spray cone.....	23
6.2.1	Finding the optimal spray cone (Power-leveling mode).....	23
6.2.2	Finding the optimal spray cone (Load-leveling mode).....	23
6.3	Carrying out a spray drying process in open mode.....	23
6.3.1	Tasks before starting spray drying in open mode.....	23
6.3.2	Preparing the instrument for open mode.....	24
6.3.3	Starting a spray drying process in open mode.....	24
6.3.4	Tasks during spray drying.....	24
6.3.5	Ending a spray drying process in open mode.....	24
6.3.6	Shutting down the instrument.....	25
6.4	Carrying out a spray drying process in closed loop mode.....	25
6.4.1	Tasks before starting spray drying in closed mode.....	25
6.4.2	Preparing the instrument for closed mode.....	25
6.4.3	Starting a spray drying process in closed mode.....	26
6.4.4	Tasks during spray drying.....	26
6.4.5	Ending a spray drying process in closed mode.....	26
6.4.6	Shutting down the instrument.....	27
7	Cleaning and servicing.....	28
7.1	Regular maintenance work.....	28
7.2	Cleaning the ultrasonic nozzle.....	28
8	Help with faults.....	30
8.1	No liquid delivery.....	30
8.2	Liquid emerges unatomized.....	30
8.3	Error messages.....	30
9	Taking out of service and disposal.....	31
9.1	Taking out of service.....	31
9.2	Disposal.....	31
9.3	Returning the instrument.....	31
10	Appendix.....	32
10.1	Spare parts and accessories.....	32
10.1.1	Accessories.....	32
10.1.2	Spare parts.....	32

1 About this document

This operation manual is applicable for all variants of the instrument.

Read this operation manual before operating the instrument and follow the instructions to ensure safe and trouble-free operation.

Keep this operation manual for later use and pass it on to any subsequent user or owner.

BÜCHI Labortechnik AG accepts no liability for damage, faults and malfunctions resulting from not following this operation manual.

If you have any questions after reading this operation manual:

► Contact BÜCHI Labortechnik AG Customer Service.

<https://www.buchi.com/contact>

1.1 Warning notices in this document

Warning notices warn you of dangers that can occur when handling the device. There are four danger levels, each identifiable by the signal word used.

Signal word	Meaning
DANGER	Indicates a danger with a high level of risk which could result in death or serious injury if not prevented.
WARNING	Indicates a danger with a medium level of risk which could result in death or serious injury if not prevented.
CAUTION	Indicates a danger with a low level of risk which could result in minor or medium-severity injury if not prevented.
NOTICE	Indicates a danger that could result in damage to property.





1.2 Connected devices

In addition to these operating instructions, you should also follow the instructions and specifications in the documentation for the connected devices.

1.3 Symbols

The following symbols are displayed in this operation manual or on the device:

1.3.1 Warning symbols

Symbol	Meaning
	General warning
	Hot surface
	Dangerous electrical voltage
	Device damage

1.3.2 Mark-ups and symbols



NOTE

This symbol draws attention to useful and important information.

- ☑ This character draws attention to a requirement that must be met before the instructions below are carried out.
- ▶ This character indicates an instruction that must be carried out by the user.
- ⇒ This character indicates the result of a correctly carried out instruction.

Mark-up	Explanation
<i>Window</i>	Software Windows are marked-up like this.
<i>Tab</i>	Tabs are marked-up like this.
<i>Dialog</i>	Dialogs are marked-up like this.
<i>[Button]</i>	Buttons are marked-up like this.
<i>[Field names]</i>	Field names are marked-up like this.
<i>[Menu / Menu item]</i>	Menus or menu items are marked-up like this.
Status	Status is marked-up like this.
Signal	Signals are marked-up like this.

1.4 Trademarks

Product names and registered or unregistered trademarks that are used in this document are used only for identification and remain the property of the owner in each case.

2 Safety

2.1 Proper use

- The device has been designed and built for laboratories.
- The ultrasonic nozzle together with the ultrasonic controller are designed for spray drying purposes using the BUCHI Mini Spray Dryer B-290 and its subsystems.
- The ultrasonic nozzle together with the ultrasonic controller are designed to atomize liquids with viscosities lower or equal to 50 cps.

2.2 Use other than that intended

Use of any kind other than that described in the section Proper use Chapter 2.1 "Proper use", page 7 and any application that does not comply with the technical specifications (see Chapter 3.5 "Technical data", page 12) constitutes use other than that intended.

In particular, the following applications are not permissible:

- Use of the instrument with non-BUCHI products nor with any other BUCHI model than the Mini Spray Dryer B-290.
- Use of the instrument in an environment with a potential risk of explosion or areas which require explosion-safe apparatus.
- Use of the instrument for processing substances outside of research and development.
- Use of the instrument for food, pharmacy and cosmetic products without appropriate cleaning.
- Use of the instrument without an appropriate leading away exhaust gas from the working area.
- Use of gases with unknown chemical composition.
- Use of the instrument with organic solvents (> 20 %) without safety lamella curtain and Inert Loop B-295.
- Use of the instrument with organic solvents (> 20 %) in open mode.
- Production and processing of substances that can lead to spontaneous reactions, such as explosives, metal hydrides or solvents that can form peroxides.
- Use of the instrument with samples which produce oxygen during the processing.
- Use of the instrument with toxic substances without appropriate safety measures.
- Use of the instrument with biohazardous materials such as viruses or bacteria.
- Use of the instrument with samples which can block the feed channel of the ultrasonic nozzle.
- Use of the instrument with substances which might explode or ignite due to the processing and the selected parameters.
- Use of the instrument with corrosive samples other than the Mini Spray Dryer B-290 ACID.
- Use of the instrument with corrosive samples in closed mode.

2.3 Staff qualification

Unqualified persons are unable to identify risks and are therefore exposed to greater dangers.

The device may only be operated by suitably qualified laboratory staff.

These operating instructions are aimed at the following target groups:

Users

Users are persons that meet the following criteria:

- They have been instructed in the use of the device.
- They are familiar with the contents of these operating instructions and the applicable safety regulations and apply them.
- They are able on the basis of their training or professional experience to assess the risks associated with the use of the device.

Operator

The operator (generally the laboratory manager) is responsible for the following aspects:

- The device must be correctly installed, commissioned, operated and serviced.
- Only suitably qualified staff may be assigned the task of performing the operations described in these operating instructions.
- The staff must comply with the local applicable requirements and regulations for safe and hazard-conscious working practices.
- Safety-related incidents that occur while using the device should be reported to the manufacturer (quality@buchi.com).

BUCHI service technicians

Service technicians authorized by BUCHI have attended special training courses and are authorized by BÜCHI Labortechnik AG to carry out special servicing and repair measures.

2.4 Location of warning signs on the product

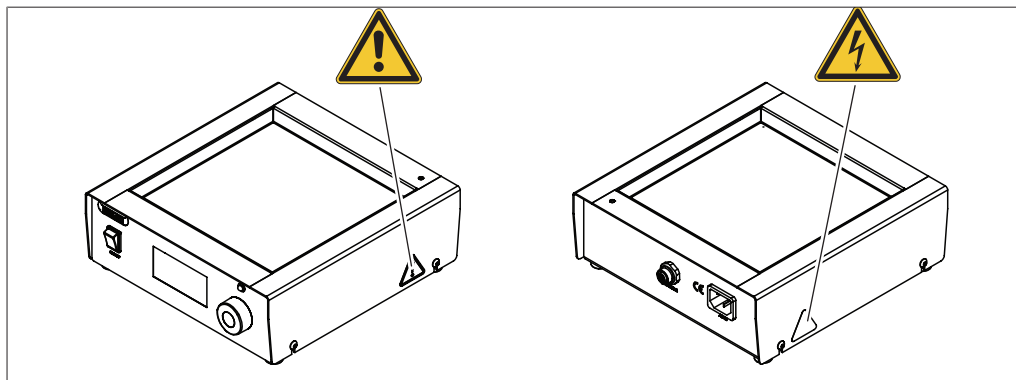

Fig. 1: Location of the warning signs



General warning



Electricity

2.5 Residual risks

The device has been developed and manufactured using the latest technological advances. Nevertheless, risks to persons, property or the environment can arise if the device is used incorrectly.

Appropriate warnings in this manual serve to alert the user to these residual dangers.

2.5.1 Faults during operation

If a device is damaged, sharp edges, moving parts or exposed electrical wires can cause injuries.

- ▶ Regularly check device for visible damage.

- ▶ If faults occur, switch off the device immediately, unplug the power cord and inform the operator.
- ▶ Do not continue to use devices that are damaged.

2.5.2 Hot surfaces

The surfaces of the device can become very hot. If touched they can cause skin burns.

- ▶ Do not touch hot surfaces or else wear suitable protective gloves.

2.5.3 Dangerous vapors

The use of the instrument can produce dangerous vapors that are capable of causing life-threatening toxic effects.

- ▶ Do not inhale any vapors produced during processing.
- ▶ Ensure that vapors are removed by a suitable fume hood.
- ▶ Only use the device in well ventilated areas.
- ▶ If vapors escape from connections, check the seals concerned and replace them if necessary.
- ▶ Do not process any unknown fluids.
- ▶ Observe the safety data sheets for all substances used.

2.6 Personal protective equipment

Depending on the application, hazards due to heat and/or corrosive chemicals may arise.

- ▶ Always wear appropriate personal protective equipment such as safety goggles, protective clothing and gloves.
- ▶ Make sure that the personal protective equipment meets the requirements of the safety data sheets for all chemicals used.

2.7 Modifications

Unauthorized modifications may impair safety and lead to accidents.

- ▶ Use only genuine BUCHI accessories, spare parts and consumables.
- ▶ Technical modifications to the device or accessories should only be carried out with the prior written approval of BÜCHI Labortechnik AG and only by authorized BUCHI technicians.

BUCHI accepts no liability whatsoever for damage arising as a result of unauthorized modifications.

3 Product description

3.1 Description of function

The ultrasonic nozzle with the ultrasonic controller are built to be used as liquid atomizer in the spray drying process with the Mini Spray Dryer B-290 and its subsystems.

An ultrasonic atomizing nozzle is a device that vibrates at frequencies beyond human hearing (>20 kHz). The vibration on the atomizing surface of the nozzle produces a low velocity spray by breaking up a liquid feed into a spray of droplets. This phenomenon is the result of the decay of an unstable capillary wave that develops in the liquid. The spray velocity is typically low with 18-36 cm/s as compared to 10-20 m/s for pressure atomizing nozzles. The ultrasonic controller provides the high frequency electrical energy required to operate the ultrasonic atomizer nozzle.

Three modes are available:

Mode	Solvent composition
Open mode	up to 20 % organic solvent
Closed mode with B-295	between 80 % - 100 % organic solvent
Closed mode with B-295 and B-296	between 20 % - 80 % organic solvent

3.2 Configuration

3.2.1 Front view ultrasonic controller

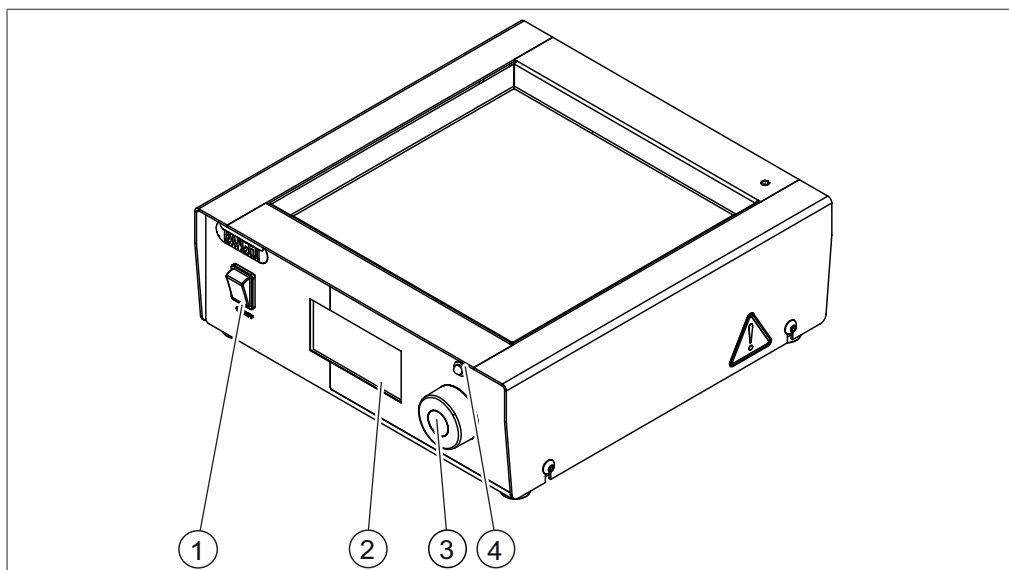

Fig. 2: Front view

- | | |
|------------------------|-----------|
| 1 On/Off master switch | 2 Display |
| 3 Navigation control | 4 LED |

3.2.2 Rear view ultrasonic controller

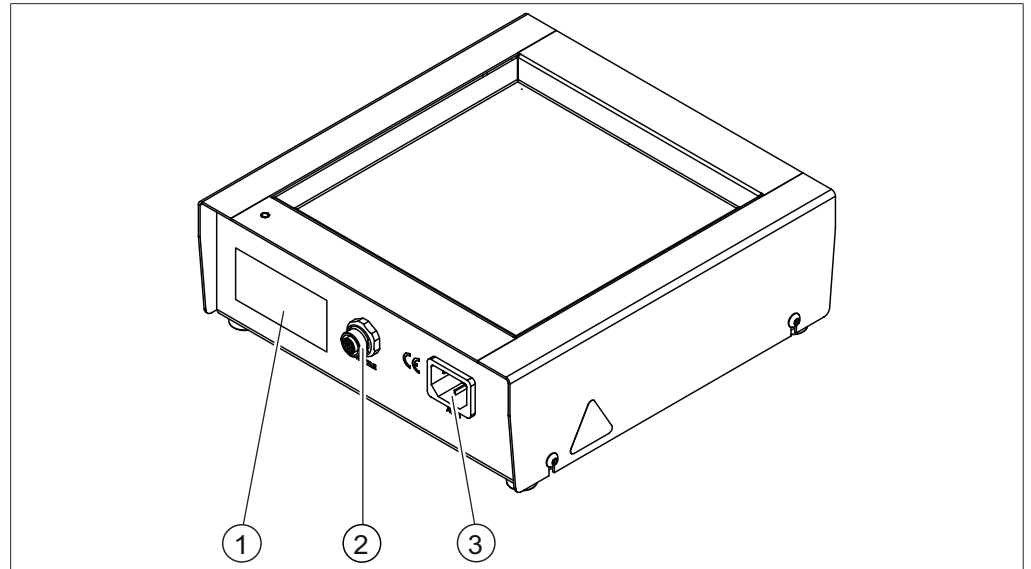

Fig. 3: Rear view

- | | | | |
|---|-------------------------|---|-----------------------------|
| 1 | Type plate | 2 | Connector ultrasonic nozzle |
| 3 | Power supply connection | | |

3.2.3 Ultrasonic nozzle

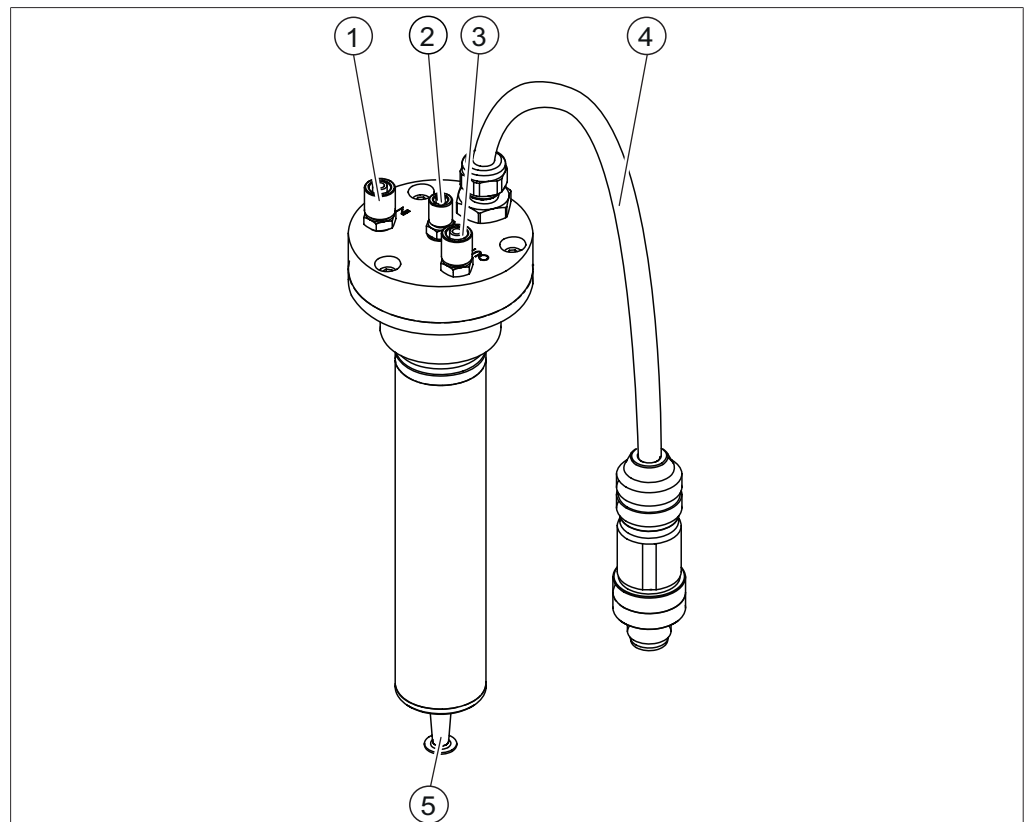

Fig. 4: Ultrasonic nozzle

- | | | | |
|---|------------------------|---|---------------------|
| 1 | Cooling gas IN | 2 | Connector feed tube |
| 3 | Cooling gas OUT | 4 | Ultrasonic cable |
| 5 | Atomizing surface | | |

3.3 Type plate

Type plate on the ultrasonic controller is located in the rear on the side .

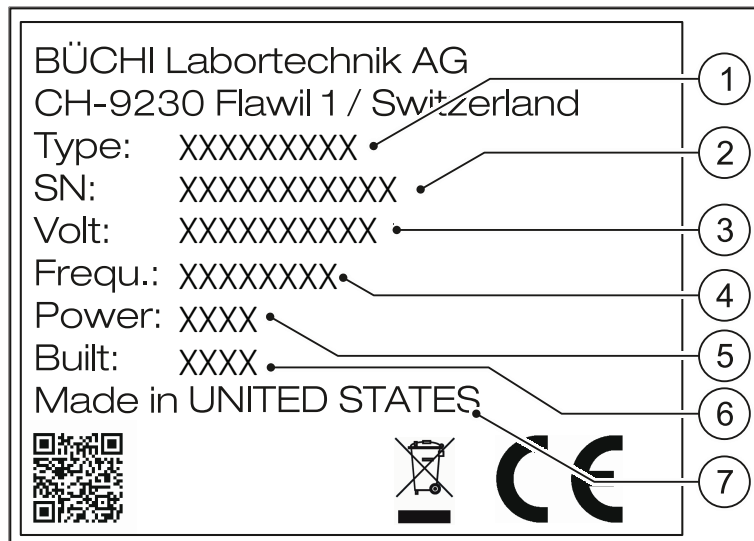

Fig. 5: Type plate

- | | | | |
|---|------------------------|---|----------------------------|
| 1 | Device name | 2 | Serial number |
| 3 | Input voltage range | 4 | Frequency of input voltage |
| 5 | Maximum power rating | 6 | Year of manufacture |
| 7 | Country of manufacture | | |

3.4 Scope of delivery



NOTE

The scope of delivery depends of the configuration of the purchase order.

Accessories are delivered as per the purchase order, order confirmation, and delivery note.

3.5 Technical data

3.5.1 Ultrasonic controller

Dimensions (W x D x H)	223 x 242 x 79 mm
Weight	1.8 kg
Connection voltage	100 - 240 ± 10 % VAC
Frequency	50 / 60 Hz
Power consumption	max. 50 W
IP Class	20

3.5.2 Ultrasonic nozzle

Maximum operating temperature of the nozzle	100 °C
Dimensions (W x D x H)	51 x 51 x 190 mm
Weight	0.54 kg
Connection voltage	23 - 25 ± 5 % VAC
Ultrasonic frequency	60 kHz

3.5.3 Ambient conditions

For indoor use only.

Max. altitude above sea level	2000 m
Ambient temperature	5 - 40°C (25°C)
Maximum relative humidity	80% for temperatures up to 31°C
Storage temperature	max. 45 °C

3.5.4 Materials

Component	Materials of construction
Ultrasonic nozzle	Titanium
	Stainless steel
Housing	Painted aluminum (chassis)
	Painted steel (cover)

4 Transport and storage

4.1 Transport

NOTICE

Risk of breakage due to incorrect transportation

Make sure that the instrument is fully dismantled.

Pack every instrument components properly to prevent breakage. Use the original packaging whenever possible.

Avoid sharp movements during transit.

-
- ▶ After transporting, check the instrument and all glass components for damage.
 - ▶ Damage that has occurred in transit should be reported to the carrier.
 - ▶ Keep packaging for future transportation.

4.2 Storage

- ▶ Make sure that the ambient conditions are complied with (see Chapter 3.5 "Technical data", page 12).
- ▶ Wherever possible, store the device in its original packaging.
- ▶ After storage, check the device for damage and replace if necessary.

5 Installation

5.1 Before installation



NOTICE

Instrument damage due to switching it on too early.

Switching on the instrument too early after transportation can cause damage.

- ▶ Climatize the instrument after transportation.

5.2 Installation site

- Place the ultrasonic controller on the product feed table of the Mini Spray Dryer B-290.



NOTE

Make sure that the power supply can be disconnected at any time in an emergency.

5.3 Establishing electrical connections



NOTE

Observe the legal requirements when connecting the instrument to the power supply.

- ▶ Use additional electrical safety features (e.g., residual-current circuit breakers) to comply with local laws and regulations.

The power supply must fulfil the following conditions:

1. Provide the mains voltage and frequency specified on the type plate of the instrument.
2. Be designed for the load imposed by the instruments connected.
3. Be equipped with suitable fuses and electrical safety features.
4. Be equipped with proper earthing.

NOTICE

Risk of property damage and diminished performance due to use of unsuitable power cables.

The power supply cables supplied with the product by BUCHI precisely match the requirements of the device. If other power cables that do not meet those requirements are used, the device may be damaged and/or its performance diminished.

- ▶ Use only the power supply cables supplied with the product or ordered separately from BUCHI.
- ▶ If using any other power supply cables, make sure that they match the specifications on the type plate.

- ▶ Make sure that all connected devices are earthed.
- ▶ If an extension lead is required, make sure that it is earthed and has a suitable power rating.
- ▶ Make sure that the power plug is freely accessible at all times.

- ▶ Plug the power cable into the connection labelled **Power IN** on the back of the instrument.
- ▶ Plug the mains plug into the power socket.

5.4 Installing the ultrasonic controller

- ▶ Place the instrument on the product feed table of the Mini Spray Dryer B-290.

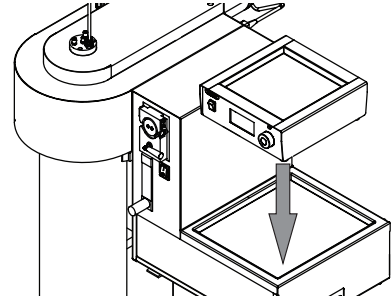

5.5 Installing the ultrasonic nozzle in open mode



⚠ WARNING

Incorrect cooling gas in open mode e.g. Nitrogen

Incorrect cooling gas can lead to unconsciousness, intoxication and other serious perils.

- ▶ Use compressed air.
- ▶ Other gases install the instrument in a fume hood.



NOTICE

Water as cooling medium

Water as cooling medium can cause an instrument damage.

- ▶ Use compressed air.

- ▶ Insert the ultrasonic nozzle into the heater element of the Mini Spray Dryer B-290.

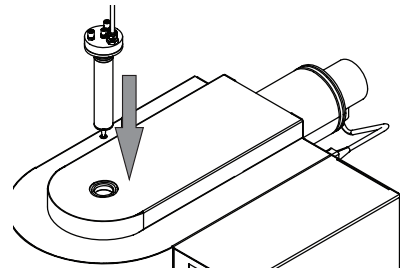

- ▶ Attach the ultrasonic nozzle with the ultrasonic nozzle cable on the ultrasonic controller.

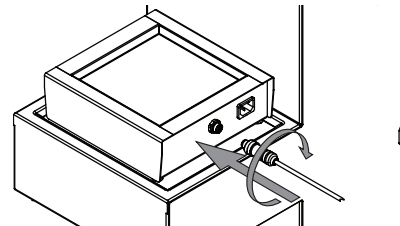

- ▶ Attach the cooling gas onto the connection marked **IN**.
- ▶ Attach the inlet tube in place with the union nut.

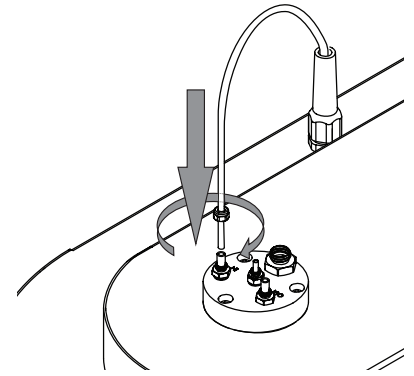

- ▶ Select a suitable type of supply hose. See resistance table of the "Operation Manual B-290 Mini Spray Dryer".
- ▶ Cut approx. 50 mm from the feeding tube.
- ▶ Attach the damper to the Y-piece.

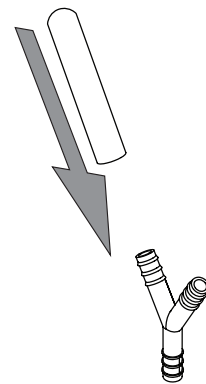

- ▶ Attach the tube piece to the Y-piece.

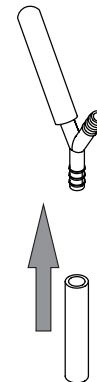

- ▶ Attach the feeding tube to the Y-piece.

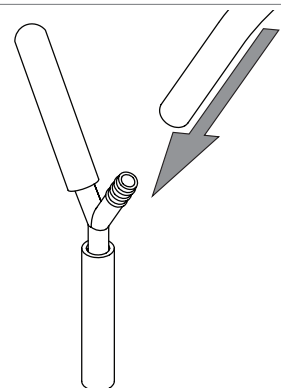

- ▶ Attach the assembled feeding tube to the nozzle.
- ▶ Attach the inlet tube in place with the union nut.

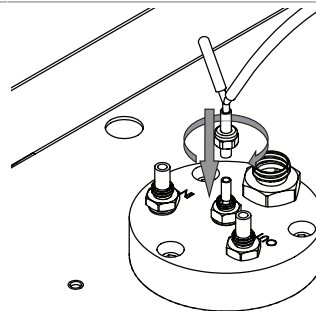

- ▶ Install the feed tube at the peristaltic pump. See operation manual Mini Spray Dryer B-290.
- ▶ Adjust the peristaltic pump bed. See "Operation Manual Mini Spray Dryer B-290 "

5.6 Installing the ultrasonic nozzle in closed mode



! DANGER

Incorrect cooling gas in closed mode e.g. compressed air

Incorrect cooling gas can lead to an potential explosive environment.

- ▶ Use inert gas.



NOTICE

Water as cooling medium

Water as cooling medium can cause an instrument damage.

- ▶ Use compressed air.

- ▶ Insert the ultrasonic nozzle into the heater element of the Mini Spray Dryer B-290.

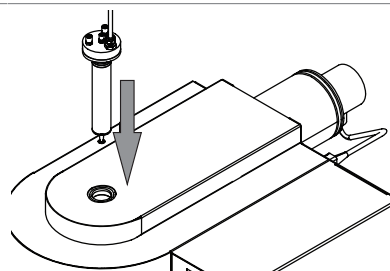

- ▶ Attach the ultrasonic nozzle with the ultrasonic nozzle cable on the ultrasonic controller.

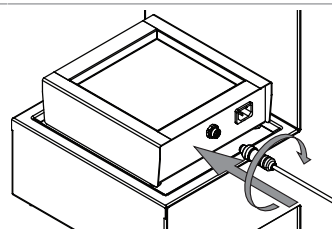

- ▶ Attach the cooling gas onto the connection marked **IN**.
- ▶ Attach the inlet tube in place with the union nut.

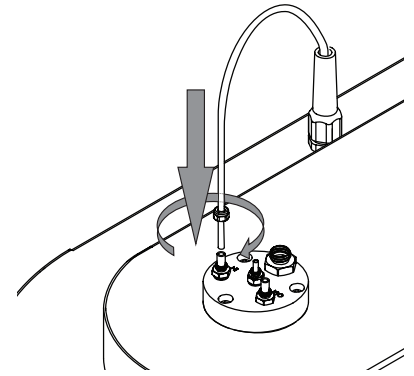

- ▶ Select a suitable type of supply hose. See resistance table of the "Operation Manual B-290 Mini Spray Dryer".
- ▶ Cut approx. 50 mm from the feeding tube.
- ▶ Attach the damper to the Y-piece.

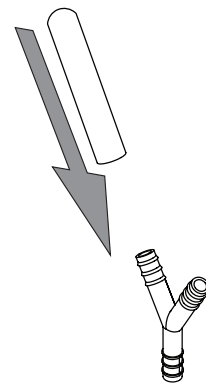

- ▶ Attach the tube piece to the Y-piece.

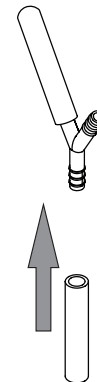

- ▶ Attach the feeding tube to the Y-piece.

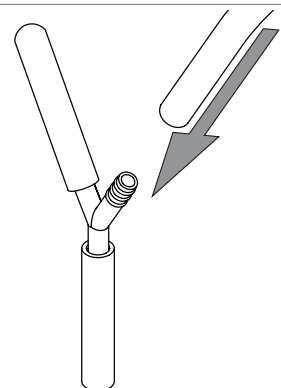

- ▶ Attach the assembled feeding tube to the nozzle.
- ▶ Attach the inlet tube in place with the union nut.

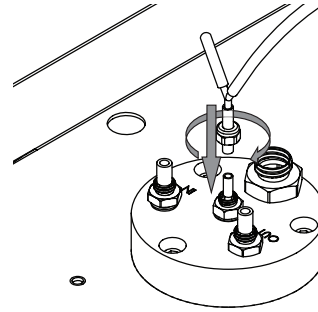

- ▶ Install the feed tube at the peristaltic pump. See operation manual Mini Spray Dryer B-290.
- ▶ Adjust the peristaltic pump bed. See "Operation Manual Mini Spray Dryer B-290 "

- ▶ Cut the drying gas hose 200 mm below the heater.

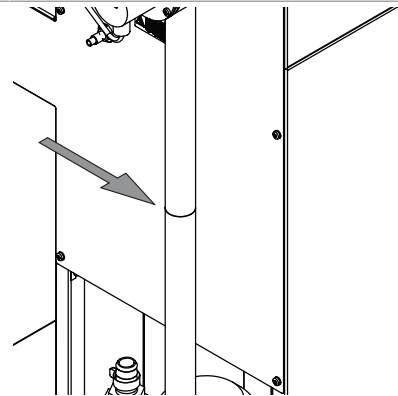

- ▶ Attach the hose connector to the inert gas adapter.

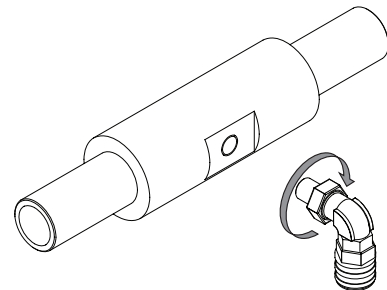

- ▶ Attach the inert gas connector to the hose.
- ▶ Attach the inert gas adapter in place with a hose clip.

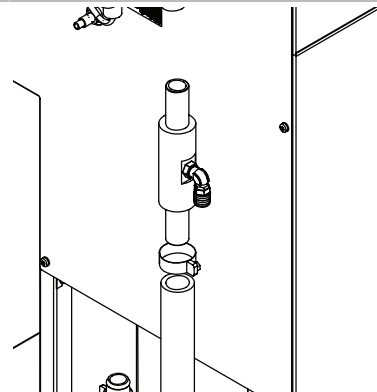

- ▶ Attach the drying gas hose to the inert gas adapter

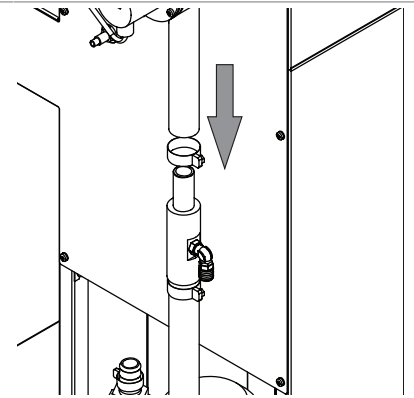

- ▶ Attach the inert gas hose to the inert gas adapter.

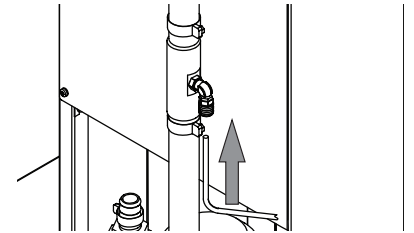

- ▶ Install the inert gas hose onto the connection marked **OUT**.
- ▶ Attach the inert gas hose in place with the union nut.

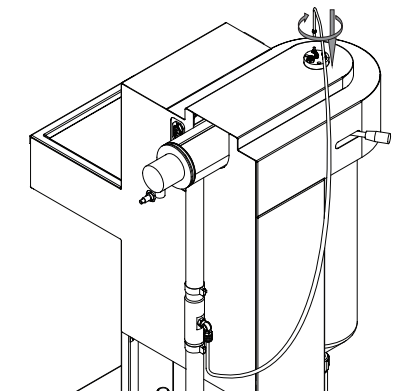
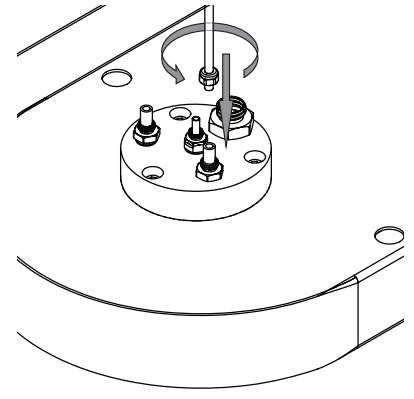

6 Operation

6.1 Operating the display

6.1.1 Layout of the display

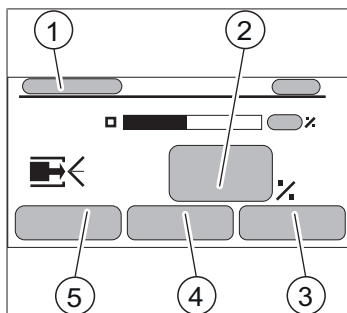

Fig. 6: Display

- | | | | |
|---|---------------------------|---|-------------------|
| 1 | Actual nozzle temperature | 2 | Set power / level |
| 3 | Info menu | 4 | Alarm screens |
| 5 | Setup menu | | |

6.1.2 Entering settings

- ▶ Use the navigation control to select the desired parameter.
- ▶ Press the navigation control to confirm the selection.

6.1.3 Selecting the operation mode

The instrument has two operation modes:

Mode	Explanation
Load-leveling mode	The ultrasonic controller compensates the load changes seen at the nozzle.
Power-leveling mode	The ultrasonic controller delivers a constant power to the nozzle.

Proceedings:

Navigation path

→ Setup → Leveling

- ▶ Navigate to the submenu Leveling according the navigation path.
- ▶ Select the mode.

- ▶ Press the button [Save].
 - ⇒ The output leveling mode is set.

6.2 Finding the optimal spray cone

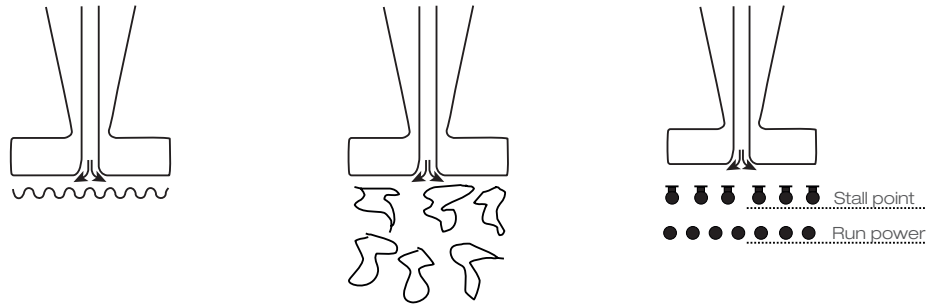

Low power

- No droplet production.

High power

- The liquid is being ripped apart.

Optimal power

- The liquid produces droplets

6.2.1 Finding the optimal spray cone (Power-leveling mode)

Precondition:

- Instrument is prepared for spraying.

- ▶ Turn the navigation control clockwise until the nozzle starts producing droplets.
- ▶ Turn the navigation control counter clockwise in 0.1 watt steps until the liquid starts to spit from the tip of the nozzle and / or flooding the tip.
 - ⇒ The stall point is found.
- ▶ Turn the navigation control 0.5 to 1.0 watt clockwise.
 - ⇒ The optimal spray cone is found.

6.2.2 Finding the optimal spray cone (Load-leveling mode)

Precondition:

- Instrument is prepared for spraying.

- ▶ Turn the navigation control clockwise until the nozzle starts producing droplets.
- ▶ Turn the navigation control counter clockwise in 1 % steps until the liquid starts to spit from the tip of the nozzle and / or flooding the tip.
 - ⇒ The stall point is found.
- ▶ Turn the navigation control 2 - 5 % clockwise.
 - ⇒ The optimal spray cone is found.

6.3 Carrying out a spray drying process in open mode

6.3.1 Tasks before starting spray drying in open mode

Precondition:

- The installation is complete. See Chapter 5.5 "Installing the ultrasonic nozzle in open mode", page 16
- ▶ Prepare 50 mL pure solvent.
- ▶ Prepare the sample.
- ▶ Place sample and solvent on top of the ultrasonic controller.

6.3.2 Preparing the instrument for open mode

	Low drying temperature ca. 80 °C	High drying temperature ca. 220 °C
Time required:	approx. 15 min	approx. 30 min

- ▶ Switch the On/Off master switch of the Mini Spray Dryer B-290 to On.
 - ⇒ The instrument is starting up.
- ▶ Set the flow on the rotameter between 50 - 60 mm.
 - ⇒ The cooling gas cools the ultrasonic nozzle.
- ▶ Select the aspirator power.
- ▶ Tap the button main switch aspirator.
 - ⇒ Drying gas is flowing in the drying circuit.
- ▶ Select the inlet temperature.
- ▶ Tap the button main switch heater.
 - ⇒ The drying gas heats up.
- ▶ Wait until the system is in steady conditions.

6.3.3 Starting a spray drying process in open mode

Precondition:

- The instrument is prepared. See Chapter 6.3.2 "Preparing the instrument for open mode", page 24
- ▶ Immerse the tube in the pure solvent.
- ▶ Set the peristaltic pump between 3 - 30 %.
- ▶ Tap the button main switch peristaltic pump.
 - ⇒ Pure solvent flows to the nozzle.
- ▶ Wait until the solvent reach the atomizing surface of the ultrasonic nozzle.
- ▶ Switch the On/Off master switch of the ultrasonic controller to On.
- ▶ Select the output leveling mode. See Chapter 6.1.3 "Selecting the operation mode", page 22
 - ⇒ The ultrasonic nozzle vibrates at the set power level.
- ▶ Adjust the spray cone. See Chapter 6.2 "Finding the optimal spray cone", page 23

6.3.4 Tasks during spray drying

Precondition:

- The instrument is in operating conditions. See Chapter 6.3.3 "Starting a spray drying process in open mode", page 24
- ▶ Change the feed tube from the pure solvent to the sample.
 - ⇒ The sample flows though the feed tube to the nozzle.
- ▶ Turn the navigation control a small distance clockwise.
 - ⇒ Spray cone is established.

6.3.5 Ending a spray drying process in open mode

Precondition:

- The sample beaker is empty.
- ▶ Change the feed tube from the sample to the pure solvent.
- ▶ Decrease the pump rate.

- ▶ Wait 2 -3 minutes.
 - ⇒ The solvent flushes the remainings from the ultrasonic nozzle.
- ▶ Tap the button main switch peristaltic pump.
- ▶ Switch the On/Off master switch of the ultrasonic controller to Off.
- ▶ Tap the button main switch heater.
- ▶ Wait until the glassware cooled down.
- ▶ Tap the button main switch aspirator.
- ▶ Set the air flow on the rotameter to 0.
- ▶ Remove the product from the product collection vessel.

6.3.6 Shutting down the instrument

Precondition:

- The spray drying process is finished. See Chapter 6.3.5 "Ending a spray drying process in open mode", page 24
- ▶ Switch the On/Off master switch of the Mini Spray Dry B-290 to Off.
- ▶ Clean the ultrasonic nozzle. See Cleaning and servicing
- ▶ Clean the Mini Spray Dryer B-290. See "Operation Manual Mini Spray Dryer B-290"

6.4 Carrying out a spray drying process in closed loop mode

There are two different modes closed mode:

	Closed mode with B-295 and B-296	Closed mode with B-295
Instruments required	Mini Spray Dryer B-290	Mini Spray Dryer B-290
	Inert Loop B-295	Inert Loop B-295
	Dehumidifier B-296	

6.4.1 Tasks before starting spray drying in closed mode

Precondition:

- The installation is complete. See Chapter 5.6 "Installing the ultrasonic nozzle in closed mode", page 18
- ▶ Prepare 50 mL pure solvent.
- ▶ Prepare the sample.
- ▶ Place sample and solvent on top of the ultrasonic controller.

6.4.2 Preparing the instrument for closed mode

	Low drying temperature ca. 80 °C	High drying temperature ca. 220 °C
Time required:	approx. 15 min	approx. 30 min

- ▶ Switch the On/Off master switch of the Mini Spray Dryer B-290 to On.
 - ⇒ The instrument is starting up.
 - ⇒ The Inert Loop B-295 is starting up.
- ▶ Select the condenser temperature at the Inert Loop B-295.
- ▶ For closed mode with B-295 and B-296 switch the On/Off master switch of the Dehumidifier B-296 to On.
- ▶ Set the flow on the rotameter between 30 - 40 mm.
 - ⇒ The cooling gas cools the ultrasonic nozzle.
- ▶ Select the aspirator power.

- ▶ Tap the button main switch aspirator.
 - ⇒ Drying gas is flowing in the drying circuit.
- ▶ Wait until the oxygen level has reached < 6%.
- ▶ Wait until the signal lamp **OXYGEN HIGH** switch off.
- ▶ Wait until the signal lamp **PRESSURE LOW** switch off.
- ▶ Select the inlet temperature.
- ▶ Tap the button main switch heater.
 - ⇒ The drying gas heats up.
- ▶ Wait until the system is in steady conditions.

6.4.3 Starting a spray drying process in closed mode

Precondition:

- The instrument is prepared. See Chapter 6.4.2 "Preparing the instrument for closed mode", page 25
- ▶ Immerse the tube in the pure solvent.
- ▶ Set the peristaltic pump between 3 - 30 %.
- ▶ Tap the button main switch peristaltic pump.
 - ⇒ Pure solvent flows to the ultrasonic nozzle.
- ▶ Wait until the solvent reach the atomizing surface of the ultrasonic nozzle.
- ▶ Switch the On/Off master switch of the ultrasonic controller to On.
- ▶ Select the output leveling mode. See Chapter 6.1.3 "Selecting the operation mode", page 22
 - ⇒ The ultrasonic nozzle vibrates at the set power level.
- ▶ Adjust the spray cone. See Chapter 6.2 "Finding the optimal spray cone", page 23

6.4.4 Tasks during spray drying

Precondition:

- The instrument is in operating conditions. See Chapter 6.3.3 "Starting a spray drying process in open mode", page 24
- ▶ Change the feed tube from the pure solvent to the sample.
 - ⇒ The sample flows though the feed tube to the nozzle.
- ▶ Turn the navigation control a small distance clockwise.
 - ⇒ Spray cone is established.

6.4.5 Ending a spray drying process in closed mode

Precondition:

- The sample beaker is empty.
- ▶ Change the feed tube from the sample to the pure solvent.
- ▶ Decrease the pump rate.
- ▶ Wait 2 -3 minutes.
 - ⇒ The solvent flushes the remainings from the ultrasonic nozzle.
- ▶ Tap the button main switch peristaltic pump.
- ▶ Switch the On/Off master switch of the ultrasonic controller to Off.
- ▶ Tap the button main switch heater.
- ▶ Wait until the glassware cooled down.
- ▶ Tap the button main switch aspirator.
- ▶ Set the air flow on the rotameter to 0.
- ▶ Remove the product from the product collection vessel.

6.4.6 Shutting down the instrument

Precondition:

- The spray drying process is finished. See Chapter 6.3.5 "Ending a spray drying process in open mode", page 24
- ▶ Switch the On/Off master switch of the Mini Spray Dry B-290 to Off.
- ▶ For closed mode with B-295 and B-296 switch the On/Off master switch of the Dehumidifier B-296 to Off.
- ▶ Clean the ultrasonic nozzle. See Cleaning and servicing
- ▶ Clean the Mini Spray Dryer B-290. See "*Operation Manual B-290 Mini Spray Dryer*"

7 Cleaning and servicing



NOTE

Users may only carry out the servicing and cleaning operations described in this section.

Any servicing and repair work which involves opening up the casing may only be carried out by BUCHI service technicians.

- ▶ Use only genuine BUCHI consumables and spare parts in order to ensure correct operation of the device and preserve the warranty.

7.1 Regular maintenance work

Component	Action	Frequency
Housing	<ul style="list-style-type: none"> ▶ Wipe down the housing with a damp cloth. ▶ If heavily soiled, use ethanol or a mild detergent. 	Weekly
Warning symbols	<ul style="list-style-type: none"> ▶ Check that the warning symbols on the instrument are legible. ▶ If they are dirty, clean them. 	Weekly

7.2 Cleaning the ultrasonic nozzle



NOTICE

Sharp cleaning tools

Sharp cleaning tools can damage the surface.

- ▶ Do not use any sharp cleaning tools.



NOTICE

Ultrasonic bath

Cleaning the instrument in an ultrasonic bath cause damage.

- ▶ Do not put the nozzle tip more than 10 mm into the ultrasonic bath.

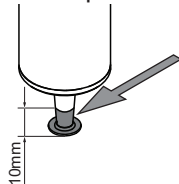



NOTICE

Liquids in cooling gas channels.

Liquids in cooling gas channels cause damage.

- ▶ Make sure that no liquids get into the cooling gas channels during the cleaning process.

Precondition:

- The ultrasonic nozzle is not installed.
- ▶ Connect a syringe with solvent to the feed tube connector.
- ▶ Press the solvent through the ultrasonic nozzle.
- ▶ Wipe down the surface of the ultrasonic nozzle with a damp cloth.

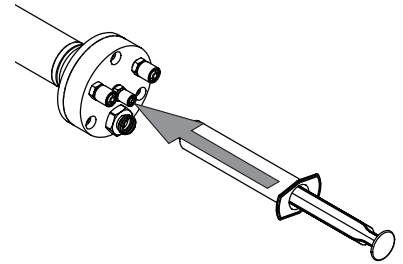

8 Help with faults

8.1 No liquid delivery

- ▶ Check the condition of the tube used in the peristaltic pump.
 - ⇒ Replace a worn out tube.
- ▶ Adjust the peristaltic pump bed. See "Operation Manual Mini Spray Dryer B-290 "

8.2 Liquid emerges unatomized

- ▶ Check if the maximum flow rate is within the rated nozzle capacity.
- ▶ Check if the feed viscosity and particle size of the slurry are within the specifications.
- ▶ Turn off the peristaltic pump.
- ▶ Switch the Ultrasonic Controller on/off for 5 times to get the liquid out of the ultrasonic nozzle, or use the damper by squeezing it.
- ▶ Adjust the spray cone. See Chapter 6.2 "Finding the optimal spray cone", page 23

8.3 Error messages

Message	Explanation	Solution
Alarm	The nozzle is not connected	▶ Connect the nozzle
	The nozzle temperature is more than 100 °C	▶ Increase the cooling supply
LED lighting	The nozzle temperature is more than 100 °C	▶ Increase the cooling supply

9 Taking out of service and disposal

9.1 Taking out of service

- ▶ Switch off the instrument and disconnect it from the mains power supply.
- ▶ Remove all cables from the device.

9.2 Disposal

The operator is responsible for proper disposal of the instrument.

- ▶ When disposing of equipment observe the local regulations and statutory requirements regarding waste disposal.
- ▶ When disposing, observe the disposal regulations of the materials used. Materials used see Chapter 3.5 "Technical data", page 12

9.3 Returning the instrument

Before returning the instrument, contact the BÜCHI Labortechnik AG Service Department.

<https://www.buchi.com/contact>

10 Appendix

10.1 Spare parts and accessories

Use only genuine BUCHI consumables and spare parts in order to ensure correct, safe and reliable operation of the system.



NOTE

Any modifications of spare parts or assemblies are only allowed with the prior written permission of BUCHI.

10.1.1 Accessories

	Order no.
Inertgas adapter	11060492

10.1.2 Spare parts

	Order no.
Y-piece	11060527
Ultrasonic controller	11069891
Ultrasonic nozzle with cable	11069893
Silicon tube D2/4	004138
Silicon cap	11060528

BUCHI Affiliates:

Europe

Switzerland/Austria

BÜCHI Labortechnik AG
CH – 9230 Flawil
T +41 71 394 63 63
F +41 71 394 64 64
buchi@buchi.com
www.buchi.com

Italy

BUCHI Italia s.r.l.
IT – 20010 Cornaredo (MI)
T +39 02 824 50 11
F +39 02 575 12 855
italia@buchi.com
www.buchi.com/it-it

Benelux

BÜCHI Labortechnik GmbH
Branch Office Benelux
NL – 3342 GT Hendrik-Ido-Ambacht
T +31 78 684 94 29
F +31 78 684 94 30
benelux@buchi.com
www.buchi.com/bx-en

Russia

BUCHI Russia/CIS
Russia 127287 Moscow
T +7 495 36 36 495
russia@buchi.com
www.buchi.com/ru-ru

France

BUCHI Sarl
FR – 94656 Rungis Cedex
T +33 1 56 70 62 50
F +33 1 46 86 00 31
france@buchi.com
www.buchi.com/fr-fr

United Kingdom

BUCHI UK Ltd.
GB – Oldham OL9 9QL
T +44 161 633 1000
F +44 161 633 1007
uk@buchi.com
www.buchi.com/gb-en

Germany

BÜCHI Labortechnik GmbH
DE – 45127 Essen
T +800 414 0 414 0 (Toll Free)
T +49 201 747 49 0
F +49 201 747 49 20
deutschland@buchi.com
www.buchi.com/de-de

Germany

BÜCHI NIR-Online
DE – 69190 Walldorf
T +49 6227 73 26 60
F +49 6227 73 26 70
nir-online@buchi.com
www.nir-online.de

America

Brazil

BUCHI Brasil Ltda.
BR – Valinhos SP 13271-200
T +55 19 3849 1201
F +55 19 3849 2907
brasil@buchi.com
www.buchi.com/br-pt

USA/Canada

BUCHI Corporation
US – New Castle, DE 19720
T +1 877 692 8244 (Toll Free)
T +1 302 652 3000
F +1 302 652 8777
us-sales@buchi.com
www.buchi.com/us-en

Asia

China

BUCHI China
CN – 200233 Shanghai
T +86 21 6280 3366
F +86 21 5230 8821
china@buchi.com
www.buchi.com/cn-zh

India

BUCHI India Private Ltd.
IN – Mumbai 400 055
T +91 22 667 75400
F +91 22 667 18986
india@buchi.com
www.buchi.com/in-en

Indonesia

PT. BUCHI Indonesia
ID – Tangerang 15321
T +62 21 537 62 16
F +62 21 537 62 17
indonesia@buchi.com
www.buchi.com/id-in

Japan

Nihon BUCHI K.K.
JP – Tokyo 110-0008
T +81 3 3821 4777
F +81 3 3821 4555
nihon@buchi.com
www.buchi.com/jp-ja

Korea

BUCHI Korea Inc.
KR – Seoul 153-782
T +82 2 6718 7500
F +82 2 6718 7599
korea@buchi.com
www.buchi.com/kr-ko

Malaysia

BUCHI Malaysia Sdn. Bhd.
MY – 47301 Petaling Jaya,
Selangor
T +60 3 7832 0310
F +60 3 7832 0309
malaysia@buchi.com
www.buchi.com/my-en

Singapore

BUCHI Singapore Pte. Ltd.
SG – Singapore 609919
T +65 6565 1175
F +65 6566 7047
singapore@buchi.com
www.buchi.com/sg-en

Thailand

BUCHI (Thailand) Ltd.
TH – Bangkok 10600
T +66 2 862 08 51
F +66 2 862 08 54
thailand@buchi.com
www.buchi.com/th-th

BUCHI Support Centers:

South East Asia

BUCHI (Thailand) Ltd.
TH-Bangkok 10600
T +66 2 862 08 51
F +66 2 862 08 54
bacc@buchi.com
www.buchi.com/th-th

Middle East

BÜCHI Labortechnik AG
UAE – Dubai
T +971 4 313 2860
F +971 4 313 2861
middleeast@buchi.com
www.buchi.com

Latin America

BUCHI Latinoamérica S. de R.L. de C.V.
MX – Mexico City
T +52 55 9001 5386
latinoamerica@buchi.com
www.buchi.com/es-es

We are represented by more than 100 distribution partners worldwide.
Find your local representative at: www.buchi.com